



Fahrzeugtechnik GmbH

Rudolf-Diesel-Str. 21-23
D-33178 Borcheln

Telefon: +49 (0) 5251/691 69 0
Telefax: +49 (0) 5251/691 69 11

E-Mail: info@waptech.de
Internet: www.waptech.de

order paper for towbeams, screwed, type B
flasks, bended

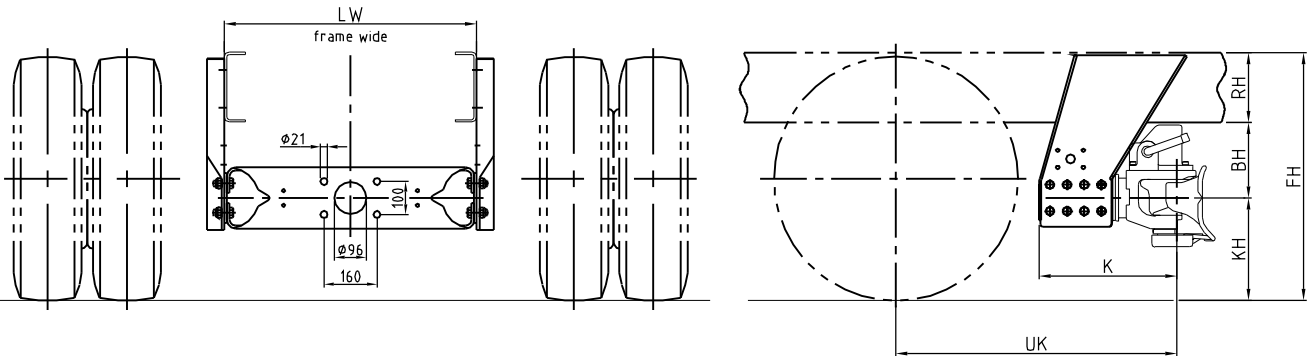

drilling pattern
(alternatively)

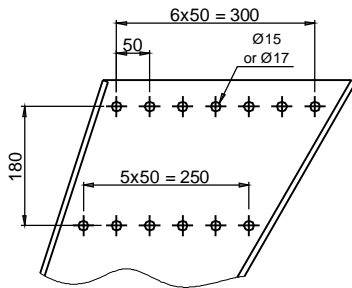

couplings

type:	measure K:
Orlandi E406	433
Orlandi E509	459
Ringfeder 2040A	437
Ringfeder 5050A	443
Rockinger 400A51	427
Rockinger 500A65	433

$$V\text{-Value} = a \times \frac{X^2}{L^2} \times C$$

C = load of the axle (kg)

- a = factor
- 1,8 for motor vehicle with air spring suspension
 - 2,4 for motor vehicle with other suspension

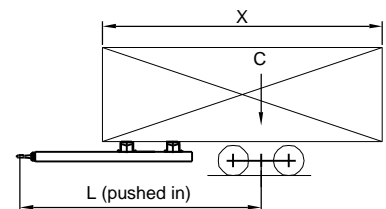

customer datas:

customer: _____ reviewer: _____ commission: _____

telephone: _____ fax: _____ delivery date: _____

Datas of the towbeams:

measure X: _____ mm	D-Value: _____ kN	measure BH: _____ mm
measure L: _____ mm	measure FH: _____ mm	coupling: _____
axel load C: _____ t	measure LW: _____ mm	vehicle type: _____
supporting load S: _____ kg	measure KH: _____ mm	drilling yes/no: ϕ _____ mm
V-Value: _____ kN	measure RH: _____ mm	quantity of order: _____
Dc-Value: _____ kN	measure UK: _____ mm	further details: _____